

August 2014

# Transit Demand Estimation And Crowding Prediction Based On Real-Time Transit Data

Michael Aro

*The University of Western Ontario*

Supervisor

Michael Bauer

*The University of Western Ontario*

Graduate Program in Computer Science

A thesis submitted in partial fulfillment of the requirements for the degree in Master of Science

© Michael Aro 2014

Follow this and additional works at: <https://ir.lib.uwo.ca/etd>

 Part of the [Computer Sciences Commons](#)

---

## Recommended Citation

Aro, Michael, "Transit Demand Estimation And Crowding Prediction Based On Real-Time Transit Data" (2014). *Electronic Thesis and Dissertation Repository*. 2217.  
<https://ir.lib.uwo.ca/etd/2217>

This Dissertation/Thesis is brought to you for free and open access by Scholarship@Western. It has been accepted for inclusion in Electronic Thesis and Dissertation Repository by an authorized administrator of Scholarship@Western. For more information, please contact [tadam@uwo.ca](mailto:tadam@uwo.ca).

TRANSIT DEMAND ESTIMATION AND CROWDING PREDICTION BASED ON  
REAL-TIME TRANSIT DATA

by

Michael Aro

Graduate Program in Computer Science

A thesis submitted in partial fulfillment  
of the requirements for the degree of  
Master of Science

The School of Graduate and Postdoctoral Studies  
Western University  
London, Ontario, Canada

© Michael Aro 2014

## Abstract

With an increasing number of intelligent analytic techniques and increasing networking capabilities, municipal transit authorities can leverage real-time data to estimate transit volume and predict crowding conditions. We introduce a proactive Transit Demand Estimation and Prediction System (TraDEPS) – an approach that has the potential to prevent crowding and improve transit service, by measuring the transit activity (the number of passengers on the individual modes of public transportation and the demand on a route), and estimating crowding levels at a given time. This system utilizes a combination of real-time data streams from multiple sources, a predictive model and data analytics for transit management. The problem of transit crowding is translated into transit activity prediction, as the latter is a straightforward indicator of the former. This thesis delivers the following contributions: (1) A crowding prediction model. (2) A system supporting the methodology. (3) A feature which displays different crowding level conditions of a route on a web map.

**Keywords:** Transit crowding, Data Analytics, Sensor, Crowd, Visualization, Algorithms, Networks, Big Data, Presence, Location, Buses, Passengers, Urban Transit Prediction

## **Acknowledgments**

I would like to start by wholeheartedly thanking my supervisor, Mike Bauer for providing feedback along the way and direction throughout my master's degree program. In all it was a great experience working with him.

I would also like to thank my dear family and friends for supporting me all the way through this thesis.

## Table of Contents

<b>Abstract .....</b>	<b>ii</b>
<b>Acknowledgments .....</b>	<b>iii</b>
<b>Table of Contents.....</b>	<b>iv</b>
<b>List of Figures .....</b>	<b>vi</b>
<b>List of Tables.....</b>	<b>vii</b>
<b>1. INTRODUCTION.....</b>	<b>1</b>
<b>1.1 Background .....</b>	<b>1</b>
<b>1.2 Motivation.....</b>	<b>5</b>
<b>1.3 Research Approach.....</b>	<b>6</b>
1.3.1 Dataset.....	6
1.3.2 Prediction and visualization.....	7
<b>1.4 Thesis Organization.....</b>	<b>8</b>
<b>2. LITERATURE REVIEW .....</b>	<b>10</b>
<b>2.1 Introduction .....</b>	<b>10</b>
<b>2.2 Data Collection Techniques .....</b>	<b>11</b>
<b>2.3 Prediction Models .....</b>	<b>12</b>
<b>2.4 Simulation Models .....</b>	<b>13</b>
<b>2.4 Summary .....</b>	<b>14</b>
<b>3. THE PROPOSED CROWDING PREDICTION MODEL.....</b>	<b>15</b>
<b>3.1 Problem definition.....</b>	<b>15</b>
<b>3.2 Applying prediction model to TraDEPS.....</b>	<b>17</b>
3.2.1 Revealing and crowding level prediction.....	17
3.2.2 Pushing analysis information to passengers .....	18
<b>4. SYSTEM DESIGN.....</b>	<b>19</b>
<b>4.1 System Architecture .....</b>	<b>19</b>

<b>4.2 Data Collection</b> .....	<b>21</b>
4.2.1 Packet Capture .....	22
4.2.2 Channel Selection .....	23
<b>4.3 Front-end Bus</b> .....	<b>24</b>
4.4 Data Filtering.....	24
4.4.1 Multiple Devices .....	27
4.5 Data encryption and decryption.....	27
4.6 Data compression and decompression.....	28
4.7 Data processing, local and cloud databases.....	29
4.8 Data output and Visualization .....	30
4.10 TraDEPS and Privacy.....	30
4.11 Summary.....	30
<b>5 PROTOTYPE IMPLEMENTATION</b> .....	<b>31</b>
<b>5.1 Prototype Implementation of Frontend Functions</b> .....	<b>31</b>
<b>5.2 Prototype Implementation of Backend Functions</b> .....	<b>34</b>
<b>5.3 Creating a Simulated Dataset</b> .....	<b>35</b>
<b>5.4 Proposed Approach for Data Analysis and Prediction</b> .....	<b>37</b>
<b>5.5 Future deployment in the Transit Office Environment</b> .....	<b>43</b>
<b>6 DISCUSSION</b> .....	<b>45</b>
<b>6.1 Benefits for Public Transit Management</b> .....	<b>45</b>
<b>6.2 Drawbacks</b> .....	<b>45</b>
<b>7 CONCLUSIONS AND FUTURE WORK</b> .....	<b>47</b>
<b>7.1 Conclusions</b> .....	<b>47</b>
<b>7.2 Contributions</b> .....	<b>48</b>
<b>7.3 Limitations</b> .....	<b>48</b>
<b>7.4 Future Work</b> .....	<b>49</b>
<b>8. BIBLIOGRAPHY</b> .....	<b>50</b>
<b>Curriculum Vitae</b> .....	<b>55</b>

# List of Figures

Figure 1-1: Transit demand compared to load capacity	8
Figure 3-1: Route 39 – Fanshawe West (London Transit).	15
Figure 3-2: Levels of analysis	16
Figure 4-1: System architecture of the TraDEPS	20
Figure 4-2: IEEE 802.11 Frame [42].	23
Figure 4-3: Wi-Fi channels in the 2.4 GHz band (Wikipedia).	24
Figure 4-4: Computing passenger state	26
Figure 4-5: Encryption-Decryption flow [43].	28
Figure 4-6: End-to-end architecture of TraDEPS	29
Figure 5-1: Prototype of Wi-Fi sensor	32
Figure 5-2: Samsung Galaxy S4 and ALFA USB Wireless Adapter	33
Figure 5-3: Typical probe request from a Samsung device, packet capture taken from a Wi-Fi sensor, opened using Wireshark	34
Figure 5-4: Crowding level is GREEN at 9:00:00 AM showing an uncrowded bus.	42
Figure 5-5: Crowding level is YELLOW at 9:02:15 AM showing light crowding expected.	43
Figure 5-6: Crowding level is RED at 9:06:12 AM showing heavy crowding expected.	43
Figure 5-7: Crowding level is ORANGE at 9:14:50 AM showing moderate crowding expected.	43

## List of Tables

Table 3-1: Crowding level prediction.....	18
Table 4-1: Probe request interval for smartphone devices using various platforms (iOS, Android and others) – influenced by the applications running on the device and other factors.....	22
Table 4-2: Frame type and Subtype .....	25
Table 5-1: Example of real data monitored by a Wi-Fi sensor at a bus stop.....	35
Table 5-2: Example of real data stored in the backend database.....	36
Table 5-3: Simulated unfiltered data for a bus stop .....	37
Table 5-4: Simulated filtered data for bus stops.....	38
Table 5-5: Simulated data for a bus .....	39
Table 5-6: Simulated aggregated presence data for bus stops .....	40





# Chapter 1

## 1. INTRODUCTION

### 1.1 Background

It is recognized that a successful public transit system will be busy. Crowding is an unavoidable part of a public transit and one goal of transit system management should be to manage crowding and its impact. Crowding is not only caused by lack of sufficient physical infrastructure. It can result from the interruption of otherwise adequate services, or even by passenger action. Crowding has negative effects on passengers – their dwell time, travel time, and overall wellbeing. Public transit management, which often accepts crowding as unavoidable, is only short changing the public transit riders. Occasional and chronic crowding must be addressed.

Although transit crowding can be alleviated through very costly infrastructural improvement and network expansion, it can be avoided through less costly crowding relief measures. According to Veitch et al [1], increasing the frequencies of services on the network is a relatively cost-effective way of preventing overcrowding without the need for complex modeling. However, in [2], Feifei Qin painted three different scenarios of providing transit services to riders, viz.

- Accommodating as many riders as possible, which can easily cause load factor to be more than 100%.
- Accommodating fewer riders by providing more frequent services that can lead to inefficient utilization of the vehicle.
- An intermediate case, that reduces the incidence of crowding while providing an efficient usage of the transit vehicles.

The third scenario is an optimal service that can be achieved through the use of modern technology to predict when crowding will likely occur before providing a new service.

Modern public transit systems require accurate real-time data of transit amount to estimate crowding level in real-time at each route level in different municipalities. This helps to locate and avoid crowding before it occurs.

Technologies for collecting traffic data and displaying traffic conditions in real-time on major roads and highways in different countries are well established. One notable example is the Google Maps traffic [3]. There is a need for applications that can provide real-time sensing of people at each stop, estimating transit demand and providing transit conditions on each route in different municipalities.

Early methods of measuring transit demand made use of statistical models derived from data collected manually at the stops [4]. The agency deployed workers on board the vehicle along every route, who tallied the riders. Using this method of data collection, public transit managers are constrained to use data that assume fixed demand for planning, which may not be particularly accurate. Statistical model does not take into account, demand fluctuations in real time.

Turnstiles have also been used in mass transit stations as a ticket barrier and recording transit demand by counting the number of people passing through a gate [5]. The use of this method to track the number of people that enter and exit a gate may be very accurate but not very practicable in urban settings where there are open stops.

In recent times, techniques for counting people include thermal imaging, use of laser scanners and RFID [6-8]. Another interesting technique is the use of computer vision and cameras to estimate the number of people [9]. Vision-based people counting solutions using infrared sensors are used onboard public transit. With infrared sensors positioned at the front and rear of the bus, the sensors count an “on” whenever a passenger gets on the bus and an “off” when a passenger gets off the bus. Using global positioning system (GPS) or Indoor positioning system (IPS), these “ons” and “offs” are tied to each stop at

the route. The data collected can be saved to a device, or automatically transferred via an onboard interface, Wi-Fi, or GPRS. Static vision-based automatic people counting solutions have also been deployed at the train stations, metro, airport, and stops.

As the cost of technology continues to decrease and the digitization of places, and people brings the online and offline realms together, companies are beginning to realize that they know more about customers online than they do offline. In order to close the gap, companies are turning to the emerging field of location analytics. Location analytics brings the power of web analytics to the physical world. This is made possible by leveraging distributed tracking and monitoring systems, like the connected mobile devices such as smartphones, Wi-Fi networks, Bluetooth-enabled beacons, and a host of other technologies. Location analytics vendors are currently using these technologies to track customers and collect data. This field of location analytics is yet to be applied to public transit systems making it interesting for research.

An increasing number of transit riders are using smartphones and tablets to look up transit information and options instantly, wherever they are. Riders use it to look up the next arrival times, and track the current location of the next bus, tram and train as well as planning trips accordingly. Mobile ticketing has also become very popular enabling users to purchase and use electronic bus passes. Smartphones and tablets are also a tool for productivity and entertainment. These among other uses make a lot of transit riders not leave home without bringing their mobile devices when taking transit, e.g. to stops and other places in general. In [10], the Canadian Radio-television and Telecommunications Commission (CRTC) reported that the number of Canadians that own smartphones increased from 38% in 2011 to 51% in 2012. According to a report from comScore in 2013 [11], smartphone penetration has risen to 62% of the Canadian population. Smartphone penetration is continually increasing and is expected to climb to 72% in Canada this year (2014). These numbers will continue to increase as the price of low-end smartphones decreases and more subscribers using cell phones of the past make the switch to using smart cell phones with apps.

Smartphones with Wi-Fi enabled devices can now be used to detect the presence of passengers thanks to a mechanism that is common across all such devices – probe requests. Probe requests are beacons, signals or short ‘pings’ broadcasted by smartphones as they search for Wi-Fi networks. These 802.11 beacons are transmitted at regular intervals from WiFi devices and contain information that can be used to identify presence, time spent, and past passengers within range of a WiFi hotspot. These devices can now be detected by WiFi access points irrespective of its WiFi association state – meaning that even if a user does not connect his or her device to the access point, the device presence can still be detected as long as the device is within signal range and the device’s WiFi antenna is turned on. Since smartphones now have greater than 60% penetration across the general population, probe requests can be used to build and detect a statistically significant set of data regarding the presence of WiFi enabled devices within the range of a given access point located at each stop.

Even when smartphones are associated with a network, they do send signals in order to connect to an access point with a better signal strength. The signals sent out include a unique string of letters and numbers known as the MAC address, the signal strength of the smartphone, and other information that are not personal data. Using 3G/4G Wi-Fi access points as sensors to sense the smartphones that are nearby, enables the collection of smartphone data or pings as real-time public transit data and sending them to a server or cloud-based system. Transit authorities can apply this approach to public transport systems and such data can be used for planning where the transit system or parts of it have reached, or will reach maximum capacity and experience serious crowding. This approach can be used to estimate transit volumes at different stops on a route level and predict transit conditions based on real-time public transit data. We believe that this approach can be very effective because Wi-Fi is easy to install and scale and smartphones are everywhere.

While commercial solutions exist for monitoring and recording location data, they can be very expensive. In the last couple of years, low-cost computing technologies for building

devices have become common. Examples include the Raspberry Pi [12] and the Arduino [13] open source projects producing hardware for microcontroller and computer applications. Another application is the use of a mobile device with Wi-Fi card in monitor mode or the combination of a mobile device and a USB wireless adapter in monitor mode as a Wi-Fi sensor.

## 1.2 Motivation

Transit overcrowding can be pretty random. Predicting when a bus will be full and crowding will occur will make planning for it easier. A proactive Transit demand estimation and prediction system (TraDEPS) has the potential to improve transit management by dispatching additional vehicles before crowding occurs. This system will exploit currently available wireless sensing technologies and data science techniques to monitor, manage, collect and analyze data. They will also provide various levels of transit information and advice to both agencies and riders.

Transit demand estimation and prediction based on real-time transit data can be used in providing transit conditions for different modes of public transportation travel in and around a municipality. The system can utilize wireless devices to collect data and use a web framework to collate and analyze the data from different sources. Applications utilizing prediction algorithms and visualizations about the transit data will be developed. The system has the potential to reduce or eliminate transit crowding on public transportation especially buses.

Data analytics and prediction are very important in managing overcrowding. Data analytics is used to produce predictions, scores and statistics. At the core of analytics are mathematical models or algorithms that are predictive modeling techniques. For example, a crowding prediction model is developed which not only analyses the transit activity but also predicts its future for overcrowding. The model works in accordance with the result of analysis. The crowding prediction model makes use of a set of formulae to estimate or predict different crowding levels. The input data to these formulae are the values obtained

during the analysis of a particular transit activity. As future overcrowding can be predicted only after analysis, prediction has to work hand in hand with analysis. The prediction model gives a distinct color code to all the different crowding levels. These color codes help the user or transit agency to identify whether overcrowding will occur or not.

## **1.3 Research Approach**

A transit line runs as a straight-shot line passing through many residential, commercial, and industrial areas along a specific route with very frequent schedules and dozens of passengers waiting each and every time. Overcrowding warrants extra service to keep up with demand. The focus of the current research is primarily on one mode of public transportation: local buses. Many people take buses to go to work, school, commercial venues or local events, and it is among the most popular modes of public transportation including trains, light rails and subways. Buses are particularly useful in urban environments because of their flexibility to navigate the side streets in addition to the main street, provide access to more people or riders in the “remote” areas of a state, city, town or county. The simplicity of a bus also makes the bus a key component of the transit network. Buses nowadays come in all shapes and sizes, from a microbus to very long buses. However, since buses have finite capacities and some shorter in length than others, they are prone to crowding at times. By estimating the total number of passengers waiting at all the stops on a route level and comparing that with current bus capacity, we hope to provide information in terms of, when a bus will be full and an additional bus should be dispatched before crowding occurs.

### **1.3.1 Dataset**

Two different sets of data are required as part of this research. The first dataset is the local bus transit demand data that can be obtained in the real world using 3G/4G Wi-Fi sensors at each bus stop containing: [date], [time], [source MAC address], [monitoring MAC address], [signal strength], [subtype description], and [stop number]. The data from

the bus stops is collated on a central server. The second dataset is the bus data. An automatic passenger counting (APC) system exists for collecting bus data. Typical data from an APC system include the following: [route number], [number of passengers on board], [stop number], [latitude], [longitude], [arrival time], [date], and [direction of travel].

### **1.3.2 Prediction and visualization**

Buses are equipped with data collecting sensors and Wi-Fi sensors placed at bus stops to collect presence data. Data is usually collected during a particular travelling time window. For example a trip from Masonville Center to Hyde Park Seagull on Fanshawe Park West route (39) in London, Ontario can be estimated to take 17 minutes (e.g. between 9:00 AM and 9:17 AM on April 13, 2014). Presence data of the total number of passengers waiting collected from each stop for this particular trip based on a 17-minute window, will be combined with data from the bus, and analyzed. The analysis information extracted from the data including the crowding level obtained from a predictive model will be integrated into a web map or provide notification messages. From the transit operations center, the agency gets a notification or have an accurate view of the estimated crowding levels on routes that are prone to crowding, allowing the dispatch of additional bus and keeping passengers informed of the crowding level via mobile application on smartphones or agency website. The colors in Figure 1-1 indicate the entire demand on a route compared to the current load capacity of the public transit at a given time.



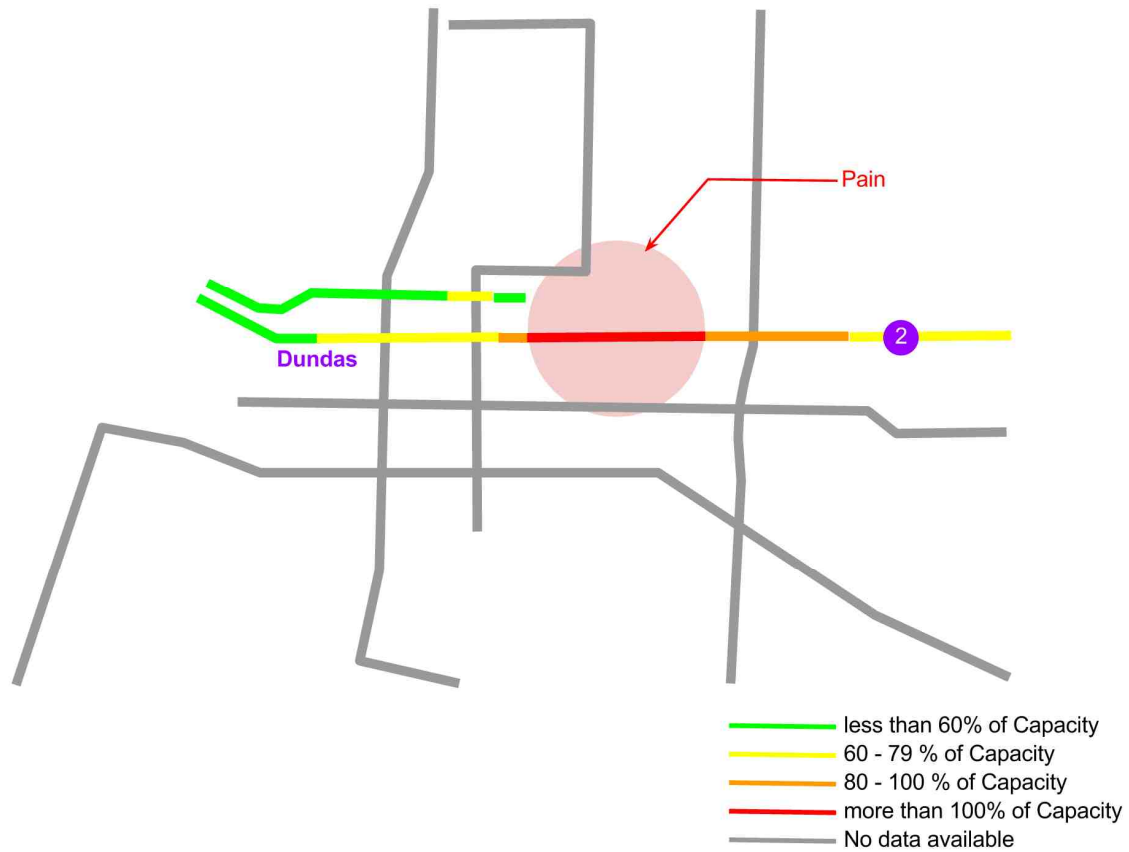

**Figure 1-1: Transit demand compared to load capacity**

Green means the bus can accommodate all the passengers currently waiting at each stop on the route without reaching capacity. The more red the road becomes, the more crowded the bus will be. Gray indicates there is no available data.

## 1.4 Thesis Organization

This section describes the contents of each chapter. The thesis consists of 7 chapters including the introductory chapter.

In Chapter 2, we review existing literature on some of the major applications and data collection schemes in public transportation, followed by an overview of prediction and simulation models.

In Chapter 3, we focus our discussion on the crowding prediction model, providing a detailed definition of the crowding problem, alongside revealing crowding levels and pushing analysis information to passengers.

In Chapter 4, we provide an overview of the system architecture.

In Chapter 5, we dive into the prototype implementation of the frontend and backend functions. We describe the structure of the data collected from the bus and bus stop. Also, we describe an approach for solving transit crowding.

In Chapter 6, we discuss the benefits and drawbacks of using our approach.

In Chapter 7, we conclude by reiterating the key points of the research and discussing threats to the validity of our results as well as ideas for extending the research in the future.

# Chapter 2

## 2. LITERATURE REVIEW

### 2.1 Introduction

Transit demand estimation and crowding level predictions have gained attention because of the increasing demand to capture high-quality, real-time data to enable intelligent transit systems in order to meet the need by transit agencies to improve quality of transit services and support transit operations and management. Data collected can include data on the location of multi-modal public transit vehicles (buses, trams, rails, ferries, etc.) from GPS and embedded systems and data from infrastructure and smartphones of riders – known as crowd sourced data.

The Advanced Traveler Information System (ATIS) is one of the core components of the Intelligent Transport System (ITS). ATIS is a means of gathering static and real-time data, analyzing and distributing real-time information to the public or private. The system depends on modern technologies, mainly wireless, to capture data. Transit data can be captured using an array of sensors. Information can be distributed to users through the web, smartphones and tablets. The information provided can be of great benefit such as to provide increased safety, management of capacity, etc. [14]. Data can be historical or real-time. Historical data is captured in previous time periods. Real-time data contains the most up-to-date data. Based on captured data, prediction information can be made. There are essentially two types of prediction information – namely long term and short term. The long-term prediction information is used for transit planning and is suitable for use in determining future supply and demand of transit conditions. The short-term prediction

information is suitable for transit management and is applicable to activities within a time frame of some seconds to few hours. Short-term predictions of transit conditions are needed for transit management and traveler information systems.

## 2.2 Data Collection Techniques

One of the early works on automated transit data collection is the estimation of passenger loads, passenger miles and origin-destination patterns using location-stamped farebox transactional data. “Transactional data” means a record is kept of each farebox transaction – essentially each boarding. “Location-stamped” means the records contain the location where the boarding occurs; the most recent stop at which the door is opened. In order to measure passenger loads, passenger miles and origin-destination patterns; records of passenger boardings as well as passenger alightings by each bus stop are very important. Providing a location-stamp requires an automatic vehicle location (AVL) system and its integration with the electronic farebox. According to Navick and Furth in [15], for both effective transit planning and operation, transit agencies need not just data on how many passengers they are carrying, but on where the passengers boarded and alighted. This data is used to estimate system-wide passenger miles and a measure of system use.

TravLink clearly showed the potential advantages of using automatic vehicle location (AVL) at an early stage. It provided location information to riders before they board by capturing data and transferring the data using AVL transmitters to an online service for processing [16].

Seattle Wide-Area Information For Travelers (SWIFT) project included a Global Positioning System (GPS) that determined location and provided direction for drivers based on pre-selected destination [17].

Real time arrival information enhances the usability of the public transit [18]. In [19], “information technology also provides the single greatest opportunity to enhance the quality of the travel experience”. Trip planning tool such as Google Transit

(<http://www.google.com/transit>), integrates automatic vehicle location and automatic passenger count data as well as station, stop, route, and schedule information from transit agencies to transit users. Providing transit traveler information improves the customer transit experience and the quality of service. While the trip planning tool can predict vehicle arrival times based on real-time GPS data, it does not support the estimation of total demand by passengers on a specific route and crowding level predictions at a given time.

## 2.3 Prediction Models

A sound prediction model can be used to precisely forecast traffic and transit conditions as well as transportation elements in real-time. Much research has been focused on prediction models for public transit and traffic systems based on historical and/or real-time data.

A large number of the prediction models are based on historical data. These include regression and historical average techniques [20-22], machine learning [23], neural networks [24-26], autoregressive integrated moving average (ARIMA) [27-29], and fuzzy logic [30-31]. These methods can be subjected to complexity in computation. This could be due to the static requirements or sizable number of estimated parameters and may not be flexible to change in transportation patterns [32].

Smith et al. [33] carried out comparisons of time series, neural network, historical average, and regression, and discovered that the non-parametric regression model notably performed better than the other models. However, non-parametric regression models involve a training process and sizable amount of historical data. If the matches are not good enough in the historical data store, the regression may not provide a reliable prediction. Therefore to make prediction accuracy better, different models were proposed based on real-time traffic data [34-35].

A varying degree of accuracy has been achieved by these prediction models for predicting arrival time, traffic state estimation, travel time, etc. However, some of the

models are based on traffic theory that is originally established for traffic systems and does not necessarily hold for transit systems. In our work, we adopt a modeling approach similar to Google traffic to develop a transit prediction model to facilitate estimation of crowding levels.

According to [36] Google Maps displays real-time traffic information across many countries. One of the layers on Google Maps illustrates colors of the roads in green, yellow, red, or gray. The colors represent how fast the traffic is moving as follows:

- Green: more than 50 mi/h
- Yellow: 25 – 50 mi/h
- Red: less than 25 mi/h
- Gray: no data available

The traffic availability data that are provided for the roads are aggregated from several sources including road sensors and cell phone users as traffic volunteers. Providing this information helps Google traffic users to avoid congested roads.

## 2.4 Simulation Models

Simulation is one of the best tools to reproduce transportation information, if there are no adequate transportation measurements available for estimation and prediction.

Transportation data can be measured using different types of equipment but it is very costly to install, test and maintain a large-scale system. For experimental purposes or proof of concept, a simulation model [37] can be used to simulate large metropolitan areas with many travelers.

Simulation models can be macroscopic or microscopic. In freeway traffic, microscopic models can represent individual vehicle movements. Macroscopic models represent traffic flow in terms of aggregate measures such as density, flow rate, and space mean

speed. A microscopic model requires more computing time and resources. It can typify vehicles in a more pragmatic manner than the macroscopic models. Microscopic models theoretically are more reactive to dissimilar traffic strategies and can also produce more accurate measure of effectiveness and give adequate flexibility to test myriad combinations of supply and demand [38].

## 2.4 Summary

The basic model for predicting when the bus will be full is decided based on the literature review. A new approach to predict ahead of time when a bus will be full is proposed based on real-time data. This is done by estimating the total number of passengers present at the bus stops on a specific route using Wi-Fi sensors and determining the total number of passengers on a bus for the route using on-board sensors. Since the real-world data may be unavailable, a simulated dataset is proposed to emulate transit operations. We will combine this data and apply the prediction model to estimate crowding level conditions at a given time for the route.

# Chapter 3

## 3. THE PROPOSED CROWDING PREDICTION MODEL

### 3.1 Problem definition

Crowding is calculated on a route basis. This means that for a given route between the origin and destination, the entire demand and the entire capacity over that route is used to determine the level of crowding over the route. For each route, there is an origin-destination pair. For example, the starting point on Route 39 of the transit network is Masonville center and the destination point is Hyde Park Seagull (see Figure 3-1).

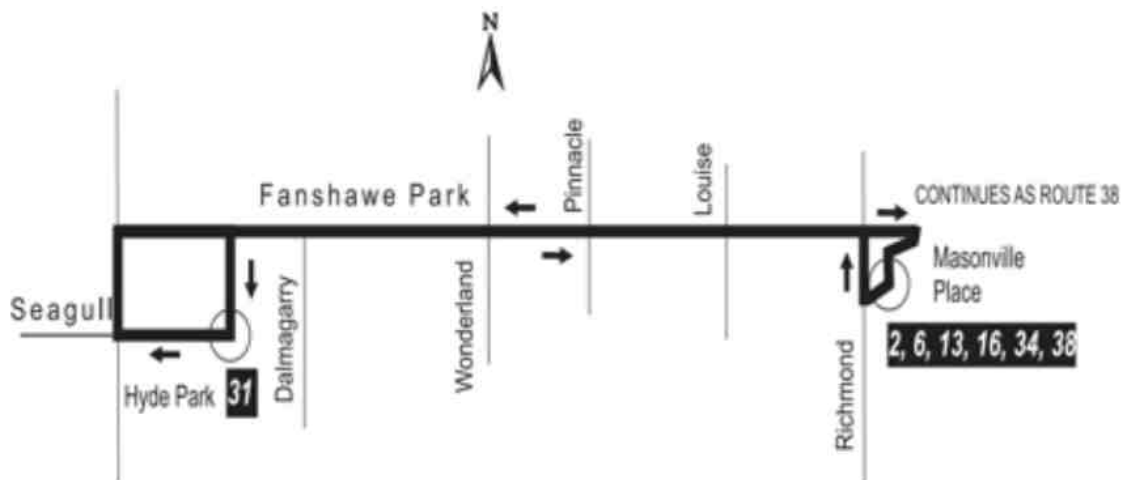

Figure 3-1: Route 39 – Fanshawe West (London Transit).



The goal of our problem are to determine the number of passengers on a bus and estimate the demand on a route in urban transit network based on real-time transit information and predict or estimate the crowding level at a given time before crowding occurs.

We assume in an urban network there is a centralized transit operation center that periodically determines transit activity and generates crowding predictions. The operation center considers the transit network as a discrete-time system to conduct the prediction. In other words, the time horizon for a particular window as shown in Figure 3-2, is divided into discrete transit prediction time intervals called a *time segment*. Transit prediction is performed repeatedly for every time segment in seconds from the beginning of the trip. In practice, the transit operation center needs to carefully decide on the value of the time segment to ensure effective and feasible prediction. If the time segment is too long, the prediction output cannot ease timely transit management. On the other hand, if the time segment is too short, the new round of prediction is not meaningful, as new transit data will not have become available at the transit operation center.

We assume there are bus data collection sensors and Wi-Fi sensors at each stop and each sensor provides transit data at given time interval, the different levels of analysis of the short-term crowding problem are illustrated graphically in Figure 3-2.

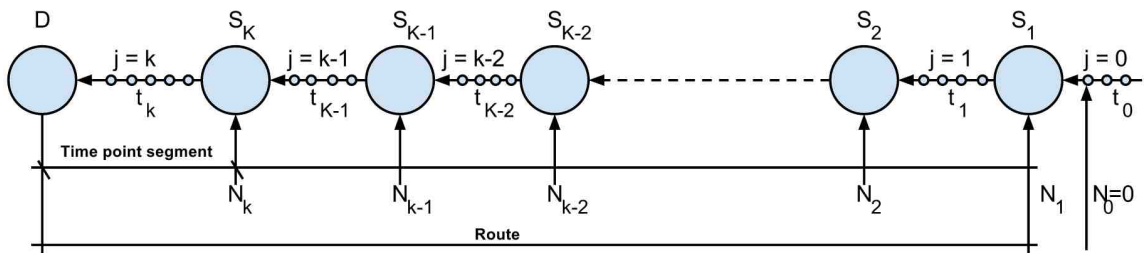

**Figure 3-2: Levels of analysis**

A stop refers to a bus stop - the point at which the door is opened for passenger boarding and alighting. S<sub>1</sub> is the origin while D is the destination. There are **k** stops between the origin of a trip and its destination in a route. A time point segment denoted by *j*, is the section of a trip from when the bus departs a bus top and arrives at the next consecutive stop. A time point segment can be divided into smaller time intervals called time points

denoted by  $t$  in the diagram. Bus data is measured at time points and passenger presence is measured at the stops. Bus data collected within a time point segment is combined with the total number of passengers waiting at the stops that are ahead of that particular time point segment.  $N_K$  refers to the number of passengers present at a stop.  $N_0$ , with value taken to be zero, is the number of passengers before the origin of the trip.

## 3.2 Applying prediction model to TraDEPS

We apply the proposed transit crowding prediction model to a typical centralized Transit Demand Estimation and Prediction System (TraDEPS) to construct a proactive TraDEPS. The proposed TraDEPS operates in two phases: (1) revealing and crowding level prediction, and (2) pushing analysis information to passengers. Each of the phases is described in detail below:

### 3.2.1 Revealing and crowding level prediction

TraDEPS periodically collects transit data, e.g. the number of passengers on the bus and the entire number of passengers waiting at all the stops ahead of the current time point segment at a time  $t$ . Based on the real-time data collected, the service predicts for a route using the prediction model, and then reveals transit crowding level using the equations in Table 3-1. A bus will be crowded if Equation 1 is satisfied

$$L + \sum_{i=j}^{k-1} N(t+1) > 100\% \text{ of } C \quad (1)$$

Here  $L$  is the current number of passengers on a bus,  $C$  is the capacity of the bus,  $j$  is the current time point segment during which crowding level is measured.  $k$  is the number of bus stops on the route.  $N(t+1)$  is the consecutive stop after the current time point segment,  $j$ .

Based on this condition, the agency can react in real time to the shift in transit amount by dispatching an additional bus.

The proposed crowding level can be represented mathematically as shown in Table 3-1:

**Table 3-1: Crowding level prediction**

Crowding Level	Transit Condition (at time $t_j$ )
Green	$L + \sum_{i=j}^{k-1} N(i+1) < 60 \% \text{ of } C \quad (2)$
Yellow	$(60 \% \text{ of } C) \leq L + \sum_{i=j}^{k-1} N(i+1) \leq (79 \% \text{ of } C) \quad (3)$
Orange	$(80 \% \text{ of } C) \leq L + \sum_{i=j}^{k-1} N(i+1) \leq (100 \% \text{ of } C) \quad (4)$
Red	$L + \sum_{i=j}^{k-1} N(i+1) > 100 \% \text{ of } C \quad (1)$
Gray	No data available

Here, C is the capacity of the vehicle and L is the current vehicle load

### 3.2.2 Pushing analysis information to passengers

When the service finishes the computation of all routes, it pushes the analysis information to the passengers via smartphone, website or display scenes at major stops. Analysis information is an indicator that shows the exact level of overcrowding in different colors before it occurs.

# Chapter 4

## 4. SYSTEM DESIGN

### 4.1 System Architecture

This section provides an overview of the Transit Demand Estimation and Prediction System (TraDEPS). The architecture is divided into front end to collect data and backend services for data analytics and prediction. The high-level system architecture is presented as shown in Figure 4-1:

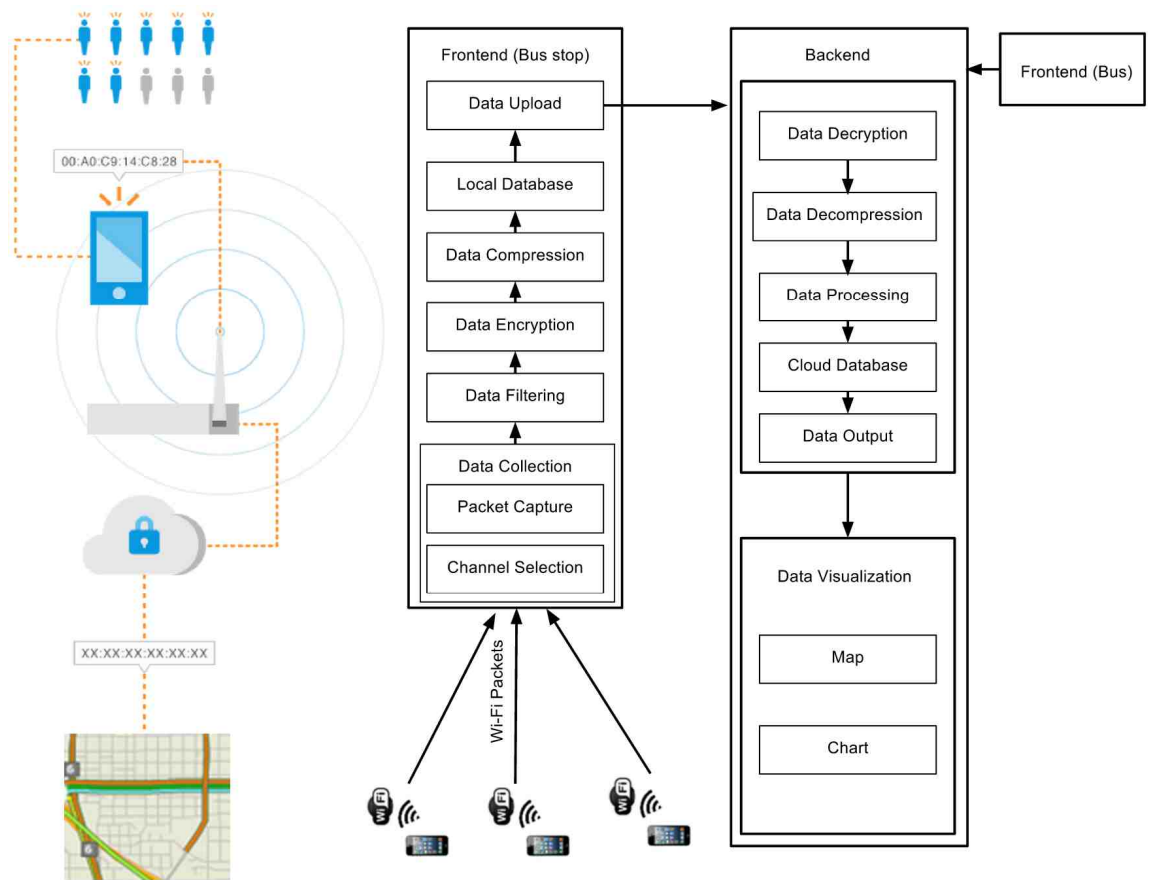

**Figure 4-1: System architecture of the TraDEPS**

The architecture of TraDEPS is divided into the front-end Wi-Fi sensing devices and the backend for data analysis and visualization. The front-end Wi-Fi sensor can be a combination of a mobile device and a long range Wi-Fi adapter in monitor mode or an ARM-based embedded device such as the Raspberry Pi. The devices can detect Wi-Fi channels and collect packets from nearby smartphones and upload to the backend server. The channel selection module selects active sniffing channel based on the configuration. The packet capture module aggregates Wi-Fi messages from Wi-Fi enabled devices nearby. The data-filtering module filters out duplicated, redundant packets, packets that are not of probe request type and packets originating from people passing by but not passengers waiting for the bus. The data encryption module encrypts the data for security and privacy during data transmission. The compression module reduces the data size before storing in local database. The data upload module uploads the Wi-Fi packets to

the backend server. We combine the data that is collected from the front-end bus sensor with the data from the bus stops.

The backend consists of a data analysis service running on the server. It provides data decryption and decompression for the filtered, encrypted and compressed messages received from the front-end devices. The data processing module processes the captured data using data analysis techniques and stores the results in the backend database. The data output module updates the data visualization module with relevant analysis results. A data visualization module can be a web or mobile interface for viewing analyzed information received from the data output module in real-time in form of charts and maps.

## 4.2 Data Collection

The data collection module consists of the IEEE 802.11 packet capture and channel selection modules. The channel selection module is used to select a channel. Wi-Fi sensors installed at each stop can be used to detect probe requests sent by WiFi enabled devices. WiFi devices including smartphones such as iPhone, Android, broadcast messages at certain intervals depending on the state of the device (see Table 4-1). Mobile devices send probe requests for network information from nearby access points or nodes. These devices need not be connected to the access points for their presence to be detected.

The data needed for the analytics include data from each bus as well as aggregated presence data from bus stops for a specific route. The data from the bus include detailed information about the load of passengers, arrival time, longitude and latitude, route number, direction of travel, and date. Usually GPS, IPS, automatic passenger counter and other onboard embedded devices are used for data collection and transmission.

Regarding the transit data for the entire demand on each route, the date, time, MAC addresses of smartphones, MAC address of Wi-Fi sensor, received signal strength indication (rssi), subtype description, and stop number can be obtained from the Wi-Fi

sensors placed at each bus stop to detect smartphone devices. Smartphones send out messages as they search for Wi-Fi networks nearby. These messages include the phone's MAC address (a unique string of letters and numbers), signal strength, and other non-personally identifiable information.

The main goal of detecting devices is to measure the number of people that are present at each bus stop and compute the total number of riders waiting on a route level at a given time allowing the study of evolution of crowding.

**Table 4-1: Probe request interval for smartphone devices using various platforms (iOS, Android and others) – influenced by the applications running on the device and other factors.**

Device State	Probe Request Interval (Smartphones)
Asleep	Approximately once a minute
Standby	9 – 16 times per minute
Connected	Varies

Wi-Fi nodes can detect probe requests from Wi-Fi devices up to 20 metres and above and upload the data to a server or cloud-based system.

#### 4.2.1 Packet Capture

The Wi-Fi sensor in the front-end is an embedded device that can capture Wi-Fi messages from Wi-Fi enabled devices in the neighborhood including probe requests from smartphones before transfer to the server or backend cloud. The packet capture module not only collects IEEE 802.11 frames or packet information, it also logs packet information locally and for immediate transfers. The network interface must be in monitor mode in order to capture all of the packets.

Each IEEE 802.11 frame has a header, a variable length payload, and a Frame Check Sequence (FCS) as shown in Figure 4-2. Frames may be control frames, data frames, or management frames. The frame is preceded by a preamble and a Physical Layer Convergence Protocol (PLCP) header, as shown below.

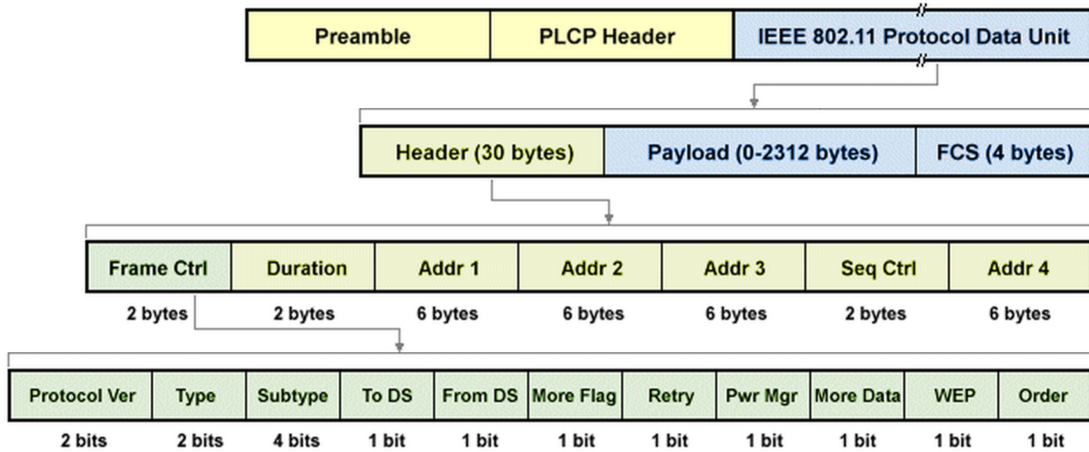
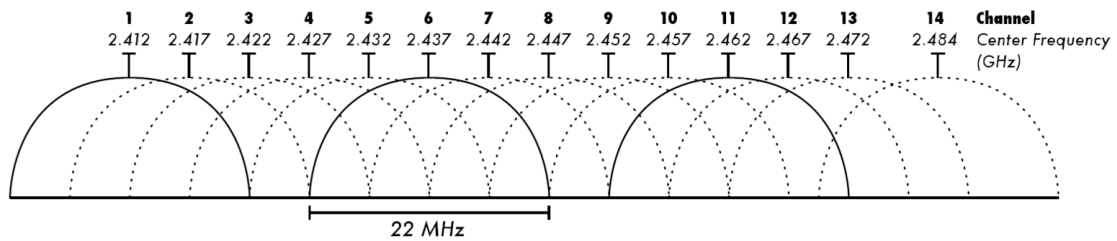

Figure 4-2: IEEE 802.11 Frame [42].

### 4.2.2 Channel Selection

In this section, we discuss the Wi-Fi channel selection for Wi-Fi message sniffing. IEEE 802.11 channels are used for data transmission. In North America, the 2.4GHz ISM band is divided into 11 channels for IEEE 802.11 wireless local area network (WLAN). All the channels are available for transmission in principle, but due to overlapping channels within an access point and adjacent channels between neighboring access points there is a possibility of interference and degraded throughput when Wi-Fi radio scans for Wi-Fi devices and available networks. While scanning, the radio quickly hops between channels. Channels 1, 6 and 11 do not overlap and should be selected at each access point that is nearby to minimize interference and low link quality. See Figure 4-3 below.





**Figure 4-3: Wi-Fi channels in the 2.4 GHz band (Wikipedia).**

Wi-Fi Channel selection monitors Wi-Fi signals and probe messages from Wi-Fi enabled devices including probe requests from smartphones. Smartphones can transmit Wi-Fi probe requests to all 11 channels and send Wi-Fi data messages in the fixed channel associated with a Wi-Fi sensor in a connected Wi-Fi network. The channel selection module chooses better active sniffing channels based on the configuration by a user.

### 4.3 Front-end Bus

Data is collected from the sensors on-board the buses and sent to the central server. The agency collects the location of a vehicle and number of passengers that are boarding and de-boarding.

### 4.4 Data Filtering

The filtering module is used to filter out packets that are not of probe request type and not originating from smartphones as well as people that are just walking by the stop but not real passengers. Once a Wi-Fi sensor has received data for period of time, computation follows including the removal of unwanted data.

The filtering module logs only those captured packets that contain probe requests from smartphone devices. All redundant, duplicated, or non-smartphone-device data packets are discarded. The filtered packet information is logged for file transfer to the backend server as an HTTP POST request. Filtering criteria are specified at runtime. As shown in

Table 4-2, all probe requests have a subtype value of “0100” in binary (4 in decimal) and a type value of “00” in binary (0 in decimal). These values can be used to filter and isolate all probe requests with 'wlan.fc.type == 0 && wlan.fc.subtype == 4'.

**Table 4-2: Frame type and Subtype**

Type Value b3 b2	Type Description	Subtype Value b7 b6 b5 b4	Subtype Description
00	Management	0000	Association Request
00	Management	0001	Association Response
00	Management	0010	Reassociation Request
00	Management	0011	Reassociation Response
00	Management	0100	Probe Request
00	Management	0101	Probe Response
00	Management	0110-0111	Reserved
00	Management	1000	Beacon
00	Management	1001	ATIM
00	Management	1010	Disassociation
00	Management	1011	Authentication
00	Management	1100	Deauthentication
00	Management	1101-1111	Reserved
01	Control	0000-1001	Reserved
01	Control	1010	PS-Poll
01	Control	1011	RTS
01	Control	1100	CTS
01	Control	1101	ACK
01	Control	1110	CF End
01	Control	1111	CF End + CF-ACK
10	Data	0000	Data
10	Data	0001	Data + CF-Ack
10	Data	0010	Data + CF-Poll
10	Data	0011	Data + CF-Ack + CF-Poll
10	Data	0100	Null Function (no data)
10	Data	0101	CF-Ack (no data)
10	Data	0110	CF-Poll (no data)
10	Data	0111	CF-Ack + CF-Poll (no data)
10	Data	1000-1111	Reserved
11	Reserved	0000-1111	Reserved

There is also a need to separate the riders waiting for public transit at a bus stop from pedestrians just passing by or outside the area. This can be determined from the signal strength and the time spent at the location. The smartphone device sending the probe requests can be classified into two different states – the passerby and the passenger state. Any device seen by the Wi-Fi node is regarded as a passerby and device seen with high signal strength for a certain time period is referred to as a passenger.

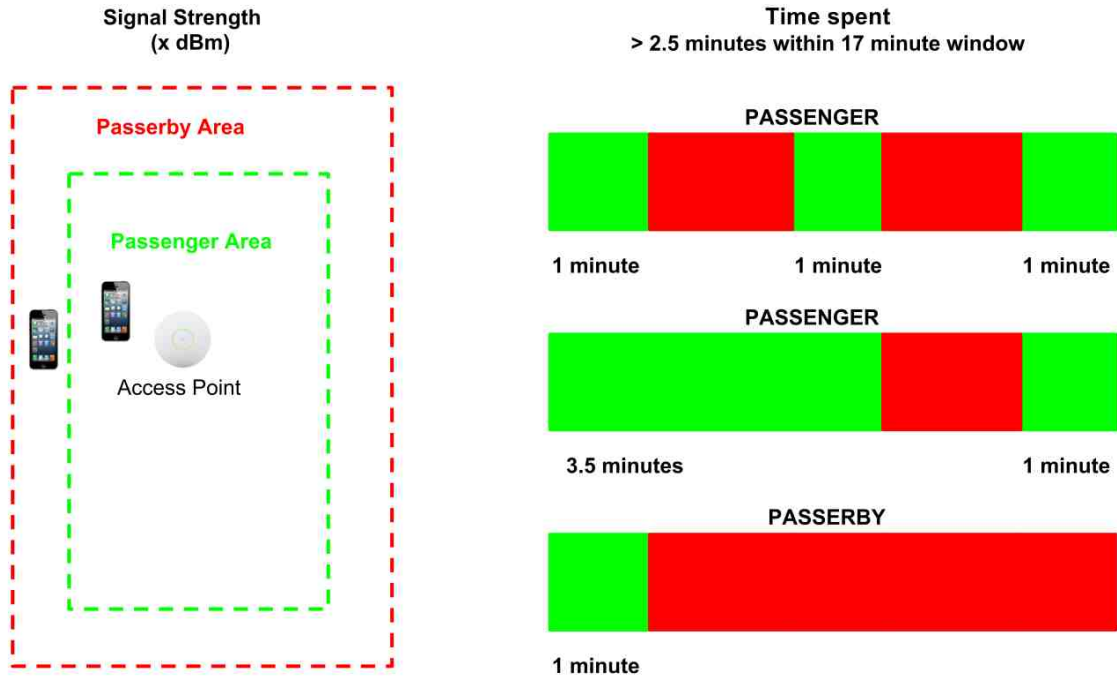

**Figure 4-4: Computing passenger state**

It is necessary to determine the people passing by the bus stop versus passengers actually waiting at the stop. The devices in passerby and passenger state can represent people passing by and the passengers waiting for bus respectively. The two different device states are computed using a variety of techniques. A passerby is any device that was seen at least once, while a passenger is any device seen for a certain time with high signal strength. Timestamps of probe requests from devices are used to compute how long someone was within the access point or Wi-Fi sensor range.

### 4.4.1 Multiple Devices

The Wi-Fi sensor cannot differentiate the type of device looking for a network. If a rider is carrying a laptop, smartphone, portable media player, and a tablet, the system will count them all. This will seriously affect the counting analytics and increase the numbers of people counted. In a real-world implementation, Wi-Fi sensors will collect millions of packets from thousands of different devices per day, week or month. The IEEE OUI Registry [39] can filter out those devices that are not smartphones before data encryption and transmission. ALGORITHM 1 shows a pseudo code to maintain a MAC library of smartphone brands in the IEEE OUI registry and dictionary of collected Wi-Fi packets. It eliminates packets that are not from smartphone devices based on the registry.

```
INPUT: oui_mac_dict: hash table of MAC library of
       smartphone brands in OUI registry:
       packet_data_dict: hash table of collected
       packets from nearby devices
OUTPUT: oui_filtered_data
(1) Get collected packets
(2) FOR i = 0; i < packet_data_dict.length; i++ DO
(3)   IF !oui_mac_dict.has_key(packet_data_dict.mac[i])
(4)     discard data
(5)   END
(6) return oui_filtered_data
```

ALGORITHM 1: Data filtering using IEEE OUI registry

## 4.5 Data encryption and decryption

Transmitted data is susceptible to eavesdropping by unauthorized users. As a result, transmitted data are subjected to encryption to ensure security and privacy of the data. Encryption is the operation of converting unhidden or plain data into hidden or cryptic data. This is done to make the data private for the recipient designated to receive it. Encryption techniques are used to protect the data transferred via wireless sensors. Each smartphone's MAC address is also scrambled or anonymized with a one-way hash.

Decryption is the process where cryptic text needs to be decrypted on the other end to be understood. Figure 4-5 shows the simple encryption-decryption flow.



Figure 4-5: Encryption-Decryption flow [43].

## 4.6 Data compression and decompression

Data gathering in a large-scale wireless sensor network depends on small and cheap devices with severe energy constraints. Network lifetime in this context is a critical concern as nodes may use up all the energy as a consequence of the high number of communications required to forward packets produced by sensors toward a data-gathering sink. Global communication and energy reduction can be obtained through in-network decentralized compression which reduces the amount of data to be sent over the network while at the same time it preserves accuracy in the reconstruction phase when data is collected at the aggregation point. Compression is a technique to reduce data into a shorter version whose length depends on the sparseness of the original. Data decompression refers to the technique for taking the compressed data and expanding it into its original form.

## 4.7 Data processing, local and cloud databases

Once received by the server or cloud-based system, the data collected from all of the sensors as shown in Figure 4-6 is aggregated. After aggregation, data from all the sensors undergo a series of computations.

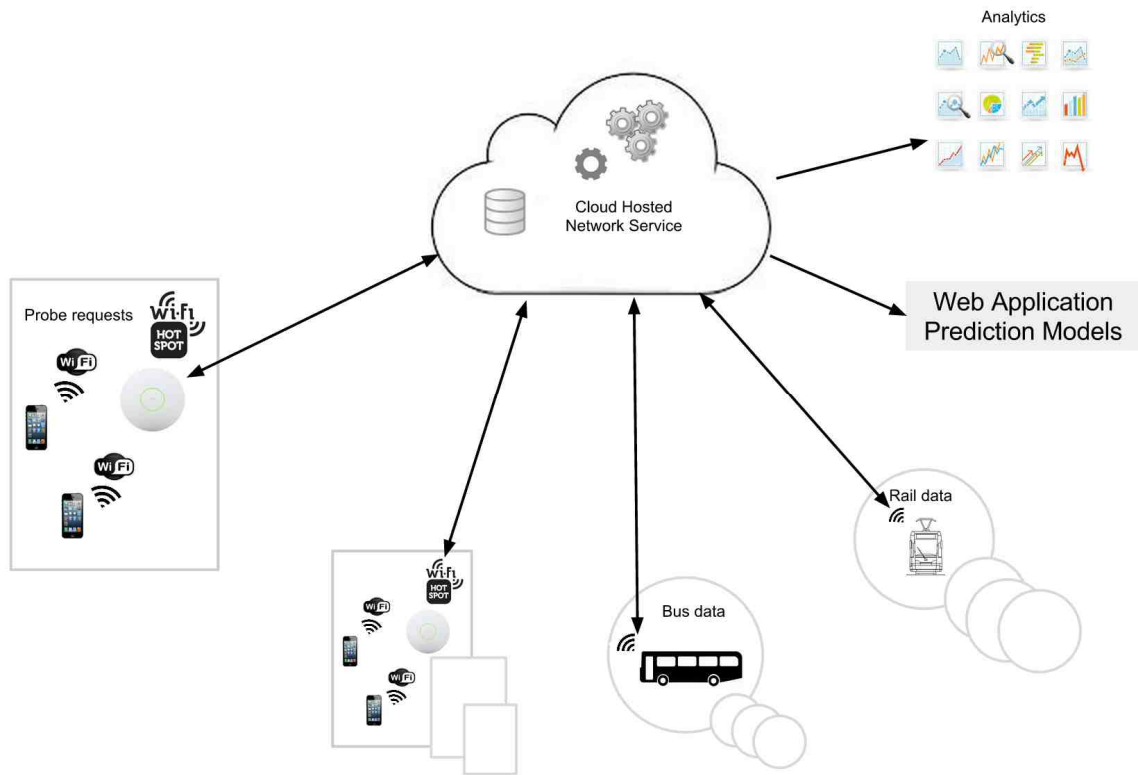

**Figure 4-6: End-to-end architecture of TraDEPS**

Filtered, encrypted and compressed data are logged into local database in addition to being transferred immediately via HTTP POST request to the server. On the server side, the web application receives the HTTP POST request, parses, decompresses and decrypts the POST data, and saves it to the server database. To assist in the data analysis, algorithms were developed to process the data received by the server.

The central server was built using Spring, a web application framework backed by MySQL. It provides the endpoint for data input. The data input receives packet information and saves it to the database. The data processing module loads the data, after which data analytics and prediction models are applied, and stores the result.

## **4.8 Data output and Visualization**

The data output module updates the data visualization module with relevant analysis results. The analysis results received from the data output module is displayed as crowding level on the server. The server presents the web interface to view the information in the form of charts and maps.

## **4.10 TraDEPS and Privacy**

The collection of location data and MAC addresses can be a concern to the riders. Therefore the issue of privacy is addressed in the TraDEPS. MAC addresses are usually processed and anonymized using a hash function by making it impossible to recover the original MAC address from the processed MAC address. At the end of each day, location data and other private information are deleted from the data store.

## **4.11 Summary**

The Transit Demand Estimation and Prediction System architecture is a centralized system for real-time data collection and analysis. We apply the proposed transit crowding prediction model to the centralized TraDEPS to construct a proactive TraDEPS. The proactive TraDEPS is of benefit in revealing and making crowding level prediction, as well as pushing analysis information to passengers.

# Chapter 5

## 5 PROTOTYPE IMPLEMENTATION

### 5.1 Prototype Implementation of Frontend Functions

In this research, we designed and implemented the front-end modules of TraDEPS for collecting data at the bus stops. The Wi-Fi sensor used to determine passenger presence at the stop consists of several modules providing functions ranging from data collection, including packet capture and data filtering, to data offload to the backend server. We explored two different front-end methods.

(1) The first method involved the use of Raspberry Pi; model B [32] with TP-LINK TL-WN722N USB Wi-Fi adapter. The Raspberry Pi Model B is a very small computer with 512MB of RAM, two usb ports, an SD card slot and runs Linux. It is based on the ARM 11 CPU 700MHz. An 8 GB SD card was used to store the operating system and software. The TP-LINK TL-WN722N USB Wi-Fi adapter was connected to the Raspberry Pi. The adapter supports monitor mode, “b”, “a”, “g”, and “n” type networks and comes with a high-gain antenna. A USB micro power supply is connected to the Pi to provide power to the Wi-Fi adapter and the Pi. An Ethernet cable was used to connect the Pi to the Internet and the local network. Probe requests captured by the Wi-Fi adapter are collected and transmitted to the server through the Ethernet cable. Figure 5-1 depicts the screen-shot of a Wi-Fi node based on the raspberry pi model B.

The software installed on the SD card includes Python, Linux and Tshark. Wireshark is a network protocol analyzer [40]. It allows the capture of packet data and filtering of data transmitted across a live network or the reading of packet data from a previously saved capture file. While Wireshark provides a GUI interface for data capture and filtering tasks, Tshark is the command-line equivalent of Wireshark. It is a perfect fit for the low-



powered Raspberry Pi, using minimal resources and allowing the data capture to be easily scripted. Python is a programming language used to control the Tshark process, handle failures, and transmit the collected data back to the central database. All data is transmitted via HTTP.



**Figure 5-1: Prototype of Wi-Fi sensor**

(2) We also used a combination of Samsung Galaxy S4 and ALFA AWUS036H USB Wireless Long-Rang WiFi network adapter as shown in Figure 5-2, as a Wi-Fi node or sensor for aggregating packets from devices equipped with Wi-Fi. The ALFA AWUS036H is a wireless USB or Wi-Fi adapter that can connect at a full 54Mbps via USB 2.0. It uses the Realtek 8187L chipset and can operate on 1 ~ 11 channels (North America), 1 ~ 13 channels (Europe) and 1 ~ 14 channels (Japan). The adapter supports monitor mode, IEEE 802.11 “b” and “g” type networks and comes with a high-gain antenna. An adapter in monitor mode can listen to all traffic and capture any packets without being associated to any network.



**Figure 5-2: Samsung Galaxy S4 and ALFA USB Wireless Adapter**

Figure 5-3 is a packet captured from a Wi-Fi sensor (ALFA AWUS036H is a wireless USB or Wi-Fi adapter), opened using Wireshark. It consists of 802.11 probe request packets. The probe request packet for a Samsung device is selected. In the figure, the source device is the client looking for a Wi-Fi sensor. The destination is broadcast ff:ff:ff:ff:ff:ff. Plus, the SSID (BSS Id) in the packet is also set to broadcast.

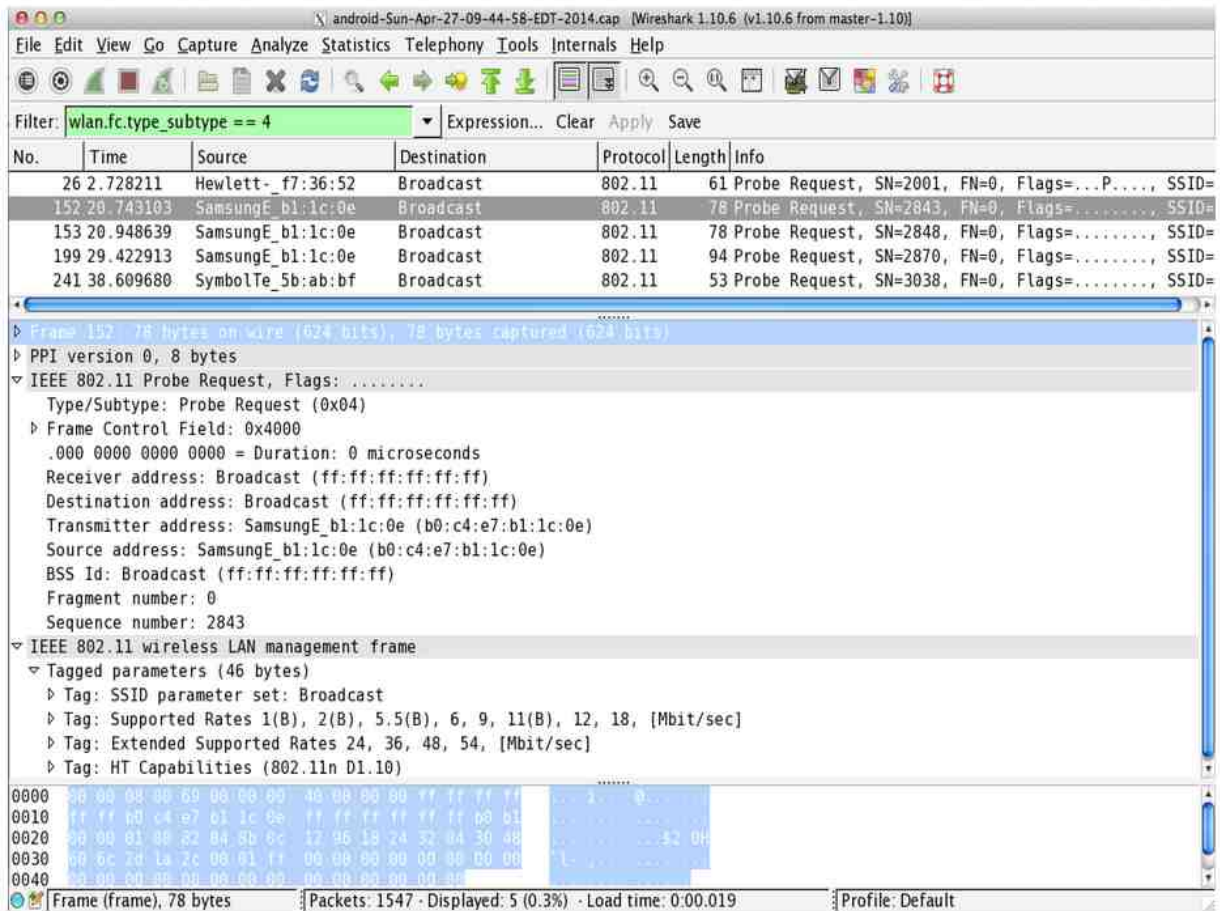

**Figure 5-3: Typical probe request from a Samsung device, packet capture taken from a Wi-Fi sensor, opened using Wireshark**

## 5.2 Prototype Implementation of Backend Functions

We designed and implemented the backend modules using Spring, a web application framework backed by MySQL. It provides the endpoint for data input from the frontend sensors as well as administrative interface to view the data collected. The Spring object relational mapping provides an easy way to run queries against the data. Also, TraDEPS provides a web portal for data visualization on Google Maps [41]. In addition, the transit operation center would get a notification message before crowding will occur.

## 5.3 Creating a Simulated Dataset

This section deals with creating new datasets. The infrastructure for collecting transit data for this research is not in place; wireless access points at each bus stop would be required. While this is not particularly costly, it was beyond the scope of the research, let alone to acquire permission from the local transit authority to install access point. In practice, data collection is distributed. The hardware used for our experiment cannot be used for data collection for all bus stops and buses in different locations, but we can use it to collect real data in a location. As a result, simulation data is the best way to produce transit information, when there are no adequate transit measurements available.

Wi-Fi enabled devices send probe requests periodically depending on the vendor. Probe requests can be typically sent between 15 seconds and 1 minute. Sniffing probe requests using hardware is an easy task since they are sent in the clear over all channels of transmission in sequence.

Table 5-1 below shows an example of probe requests sent by devices with MAC addresses **04:f0:21:09:86:d1** and **98:03:d8:7f:3c:9f**.

**Table 5-1: Example of real data monitored by a Wi-Fi sensor at a bus stop**

Frame Control	Destination address	Source address	BSS Id	RSSI	Frame Number	Arrival Time
0x4000	ff:ff:ff:ff:ff:ff	04:f0:21:09:86:d1	ff:ff:ff:ff:ff:ff	-30	103	Aug 8, 2014 13:31:30.628808000 EDT
0x4000	ff:ff:ff:ff:ff:ff	98:03:d8:7f:3c:9f	ff:ff:ff:ff:ff:ff	-32	137	Aug 8, 2014 13:31:34.065392000 EDT

The data transmitted through the WiFi sensor to the backend and stored in the database include:

- Date: when the packet is captured.

- Time: when the packet is captured.
- Mac address of the WiFi sensor or access point.
- MAC address: the mac address of the smartphone from which packets emanated.
- Received signal strength (in dBm) from the smartphone device.
- Stop Number: the stop corresponding to the WiFi sensor

Table 5-2 shows an example of real data stored in the backend database.

**Table 5-2: Example of real data stored in the backend database**

DB Id	Date	Time	Source MAC	rssi	Monitor MAC	type	Stop Number
530	2014-08-08	13:31:30	04:f0:21:09:86:d1	-30	d0:22:be:9d:0E:4A	Probe Request	702
531	2014-08-08	13:31:34	98:03:d8:7f:3c:9f	-32	d0:22:be:9d:0E:4A	Probe Request	702

We collected 751 packets sent by around 240 unique devices. The collection campaign lasted for 2 minutes at a bus stop with multiple routes. After data collection, we filtered out packets that were not probe requests. Of the 751 packets collected, 40 were probe requests. Then we built a database for each probe as identified by its MAC address (field source MAC).

Simulated datasets were created manually from scratch for the bus and bus stop. For the bus, we created simulated dataset based on the fields and not the data in the database. In the case of a bus stop, we created a simulated dataset to resemble the data collected using the front-end devices containing information for the different parameters to be measured. Based on the simulated dataset for the bus stop, we created a simulated dataset for the aggregated presence data for all bus stops. For the purposes of making one's data anonymous, this is a good thing. However, this also means that the simulated dataset will be inadequate, and parameter values may be unrealistic. It may also give prediction errors as well.

## 5.4 Proposed Approach for Data Analysis and Prediction

In proactive TraDEPS, the monitored bus and bus stops are connected to the central server or cloud based system. Sensors on the bus will send bus data including current passenger load, timestamp, location information, and direction of travel. Wi-Fi sensors at the bus stops will collect and send human presence information including the MAC address of passenger devices (sources), MAC address of Wi-Fi sensor (monitor), signal strength of passenger devices, and timestamps as shown in Table 5-3. The central server would send analysis information to web and mobile clients and possibly the digital display board next to a bus stop.

**Table 5-3: Simulated unfiltered data for a bus stop**

Date	Time	Source MAC	rsssi	Monitor MAC	Type	Stop Number
2014-04-16	8:56:00	04:2C:03:96:0E:4A	-52	00:13:03:96:0E:4A	Probe Request	1142
2014-04-16	8:56:00	A4:2C:03:96:0E:4A	-60	00:13:03:96:0E:4A	Probe Request	1142
2014-04-16	8:56:00	38:BC:03:96:0E:4A	-56	00:13:03:96:0E:4A	Probe Request	1142
2014-04-16	8:56:00	74:E5:03:96:0E:4A	-52	00:13:03:96:0E:4A	Data	1142
2014-04-16	8:56:00	A4:ED:03:96:0E:4A	-54	00:13:03:96:0E:4A	Data	1142
2014-04-16	8:56:00	D4:BE:03:96:0E:4A	-60	00:13:03:96:0E:4A	Probe Request	1142
2014-04-16	8:56:00	00:26:03:96:0E:4A	-52	00:13:03:96:0E:4A	Probe Response	1142
2014-04-16	8:56:00	08:90:03:96:0E:4A	-58	00:13:03:96:0E:4A	Data	1142
2014-04-16	8:56:00	A4:2C:03:92:0E:4A	-52	00:13:03:96:0E:4A	Data	1142
2014-04-16	8:56:00	D8:2A:7E:10:1E:63	-52	00:13:03:96:0E:4A	Data	1142
2014-04-16	8:56:00	0A:2C:03:96:0E:4A	-52	00:13:03:96:0E:4A	Data	1142
2014-04-16	8:56:00	A4:21:03:96:0E:4A	-52	00:13:03:96:0E:4A	Probe Request	1142
2014-04-16	8:56:00	B0:C4:03:96:0E:4A	-52	00:13:03:96:0E:4A	Probe Request	1142
2014-04-16	8:56:00	B1:1C:03:96:0E:4A	-54	00:13:03:96:0E:4A	Probe Request	1142
2014-04-16	8:56:00	A4:1C:03:96:0E:3A	-52	00:13:03:96:0E:4A	Probe Request	1142

In practice, data for analysis is usually collected during a particular travelling time window. For example a trip from Masonville Center to Hyde Park Seagull on Fanshawe

Park West route (39) in London, Ontario can be estimated to take 17 minutes (e.g. between 9:00 AM and 9:17 AM on April 13, 2014). Presence data at the bus stops and bus data for this particular trip will be based on a 17-minute window. Every bus and bus stop is identified by a route number and stop number respectively. In practice, a Wi-Fi sensor at the bus stop will communicate a log containing tuples of the form {date, time, source\_MAC, rssi, monitor\_MAC, type, stop\_number} to the central server (see Table 5-4). A sensor placed on the bus will communicate a log containing tuples of the form {route\_number, stop\_number, latitude, longitude, load, arrival\_time, data, direction} to the central server. From the logs, the data processing module on the server, containing a data analysis engine, will derive various information. For example, the crowding level: the degree of overcrowding expected before it actually occurs on a trip for a specific route at a given time.

**Table 5-4: Simulated filtered data for bus stops**

Date	Time	Source MAC	rssi	Monitor MAC	type	Stop Number
<b>STOP 2</b>						
2014-04-17	9:00:00	04:2C:03:96:0E:4A	-52	00:13:03:96:0E:4A	Probe Request	702
2014-04-17	9:00:00	A4:2C:03:96:0E:4A	-60	00:13:03:96:0E:4A	Probe Request	702
<b>STOP 3</b>						
2014-04-17	9:00:00	00:26:03:96:0E:4A	-52	00:13:03:96:0E:4A	Probe Request	2515
2014-04-17	9:00:00	08:90:03:96:0E:4A	-58	00:13:03:96:0E:4A	Probe Request	2515
2014-04-17	9:00:00	A4:2C:03:92:0E:4A	-52	00:13:03:96:0E:4A	Probe Request	2515
2014-04-17	9:00:00	D8:2A:7E:10:1E:63	-52	00:13:03:96:0E:4A	Probe Request	2515
2014-04-17	9:00:00	0A:2C:03:96:0E:4A	-52	00:13:03:96:0E:4A	Probe Request	2515
2014-04-17	9:00:00	A4:21:03:96:0E:4A	-52	00:13:03:96:0E:4A	Probe Request	2515
<b>STOP 4</b>						
2014-04-17	9:00:00	B0:C4:03:96:0E:4A	-52	00:13:03:96:0E:4A	Probe Request	2512
2014-04-17	9:00:00	B1:1C:03:96:0E:4A	-54	00:13:03:96:0E:4A	Probe Request	2512
2014-04-17	9:00:00	A4:1C:03:96:0E:3A	-52	00:13:03:96:0E:4A	Probe Request	2512
<b>STOP 5</b>						
2014-04-17	9:00:00	38:BC:03:96:0E:4A	-56	00:13:03:96:0E:4A	Probe Request	2505
2014-04-17	9:00:00	74:E5:03:96:0E:4A	-52	00:13:03:96:0E:4A	Probe Request	2505
2014-04-17	9:00:00	A4:ED:03:96:0E:4A	-54	00:13:03:96:0E:4A	Probe Request	2505
2014-04-17	9:00:00	D4:BE:03:96:0E:4A	-60	00:13:03:96:0E:4A	Probe Request	2505

We next show an operation analysis as example of the kinds of analyses that can be performed by using the simulated datasets in the absence of real monitoring logs. For constructing the simulated datasets, we manually created excel dataset files from scratch. Our simulation consists of ten bus stops namely: S1, S2, S3, S4, S5, S6, S7, S8, S9 and S10 with the corresponding number of passengers waiting at each bus top denoted by N1, N2, N3, N4, N5, N6, N7, N8, N9 and N10 respectively. Furthermore, the simulation consists of one bus running on one route namely Route 39: S1->S2->S3->S4->S5->S6->S7->S8->S9->S10. In the case of the simulated filtered dataset for the bus data, we randomly inserted sets of values corresponding to each parameter in the tuples of the form {route\_number, stop\_number, latitude, longitude, load, arrival\_time, date, direction} as shown in Table 5-5.

**Table 5-5: Simulated data for a bus**

Route number	Stop number	Latitude	Longitude	Load	Arrival time	Date	Direction
39	1142	43.0254714	81.2816004	8	9:00:00	2014-04-17	4
39	NA	43.0250824	81.2855363	8	9:01:35	2014-04-17	4
39	702	43.0246933	81.2894723	10	9:02:00	2014-04-17	4
39	NA	43.024436	-81.290366	10	9:02:08	2014-04-17	4
39	NA	43.02395	-81.291932	10	9:02:15	2014-04-17	4
39	2512	43.0231075	81.2948788	12	9:02:30	2014-04-17	4
39	NA	43.023793	-81.295469	12	9:02:50	2014-04-17	4
39	2515	43.0215725	81.3001718	20	9:03:00	2014-04-17	4
39	NA	43.02167	-81.304638	20	9:03:40	2014-04-17	4
39	NA	43.020011	-81.305228	20	9:04:10	2014-04-17	4
39	2505	43.0198313	81.3061591	28	9:05:00	2014-04-17	4
39	NA	43.019467	-81.307162	28	9:05:24	2014-04-17	4
39	2517	43.0189003	81.3094726	38	9:06:12	2014-04-17	4
39	NA	43.018197	-81.311797	38	9:07:04	2014-04-17	4
39	NA	43.017255	-81.314758	38	9:07:40	2014-04-17	4
39	2513	43.0166181	81.3172361	36	9:08:20	2014-04-17	4
39	NA	43.015404	-81.321152	36	9:09:00	2014-04-17	4
39	2511	43.0150505	81.3225806	33	9:10:00	2014-04-17	4
39	NA	43.012721	-81.330529	33	9:12:00	2014-04-17	4
39	1757	43.0108896	81.3339156	29	9:14:50	2014-04-17	4
39	NA	43.009089	-81.333992	22	9:16:46	2014-04-17	4
39	1653	43.0085681	81.3354958	0	9:17:00	2014-04-17	4



For the simulated dataset for the aggregated presence data from the bus stops, we randomly populated the excel file with the values corresponding to each parameter in the tuples of the form {time, N1, N2, N3, N4, N5, N6, N7, N8, N9, N10} as shown in Table 5-6. The “time” in the aggregated bus stop tuple refers to the time at which the crowding level is predicted. In practice, the data from all bus stops is collated at central server. We carried out experiments with four different time values during a 17-minute travel window. Aggregated presence data from the bus stops in Table 5-4 is combined with load data from the bus in Table 5-5, and analyzed based on the crowding prediction/estimation model.

**Table 5-6: Simulated aggregated presence data for bus stops**

Time	N1	N2	N3	N4	N5	N6	N7	N8	N9	N10
9:00:00	0	2	3	6	4	3	2	0	0	0
9:02:15	0	0	3	8	7	4	4	1	1	0
9:06:12	1	0	0	0	0	4	5	2	3	0
9:14:50	2	1	1	0	0	0	0	0	14	0

At 9:00:00 AM, the value of j, the time segment, is 0 at S1. The total number of passengers waiting at the bus stops is given by:

$$\sum_{i=0}^9 N(i+1) = N1 + N2 + N3 + N4 + N5 + N6 + N7 + N8 + N9 + N10$$

Therefore, the total number of passengers waiting at this time of measurement in aggregated presence dataset is equivalent to 20. The passenger load (L) at 9:00:00 AM is 8 from the bus dataset. The capacity of the bus is 50.

$$L + \sum_{i=0}^9 N(i+1)$$

i.e.  $8 + 20 = 28$  satisfies the transit condition in Equation 2 since  $60\%$  of  $50 = 30$  and  $28 < 30$ . At this point the crowding level is GREEN.

At 9:02:15 AM, the value of j is 2 between S2 and S3. The total number of passengers waiting at the remaining bus stops is given by:

$$\sum_{i=2}^9 N(i+1) = N3 + N4 + N5 + N6 + N7 + N8 + N9 + N10$$

Therefore, the total number of passengers waiting at this time of measurement in the aggregated presence dataset is equivalent to 28. The passenger load (L) at 9:02:15 AM is 10 from the bus dataset.

$$L + \sum_{i=2}^9 N(i+1)$$

i.e.  $10 + 28 = 38$  satisfies the transit condition in Equation 3 since 38 is 76% of 50 and 38 lies within (60 – 79) % of the capacity. At this point the crowding level is YELLOW.

At 9:06:12 AM, the value of j is 5 at S6. The total number of passengers waiting at the remaining bus stops is given by:

$$\sum_{i=5}^9 N(i+1) = N6 + N7 + N8 + N9 + N10$$

Therefore, the total number of passengers waiting at this time of measurement in the aggregated presence dataset is equivalent to 14. The passenger load (L) at 9:06:12 AM is 38 from the bus dataset.

$$L + \sum_{i=j}^9 N(i+1)$$

i.e.  $38 + 14 = 52$  satisfies the transit condition in Equation 1 since  $52 > 100\%$  of 50 and 28. At this point the crowding level is RED. This shows that the bus will be full and transit crowding will occur at some point beyond 9:06:12 AM. It is recommended that an additional bus be dispatched at that time.

At 9:14:50 AM, the value of j is 8 at S9. The total number of passengers waiting at the remaining bus stops is given by:

$$\sum_{i=8}^9 N(i+1) = N9 + N10$$

Therefore, the total number of passengers waiting at this time of measurement in the aggregated presence dataset is equivalent to 14. The passenger load (L) at 9:14:50 AM is 29 from the bus dataset.

$$L + \sum_{i=8}^9 N(i+1)$$

i.e.  $29 + 14 = 43$  satisfies the transit condition in Equation 4 since 43 is 86% of 50 and 43 lies within (80 – 100) % of the capacity. At this point the crowding level is ORANGE.

Crowding level estimates at different times are shown in Figures 5-4, 5-5, 5-6 and 5-7 below. The agency will be able to see when a bus will be full before it actually happens as shown in Figure 5-6 and dispatch an additional bus due to the expected heavy crowding.

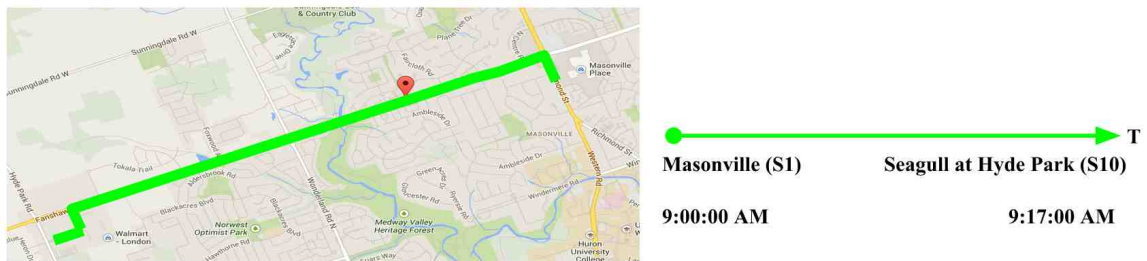

**Figure 5-4: Crowding level is GREEN at 9:00:00 AM showing an uncrowded bus.**

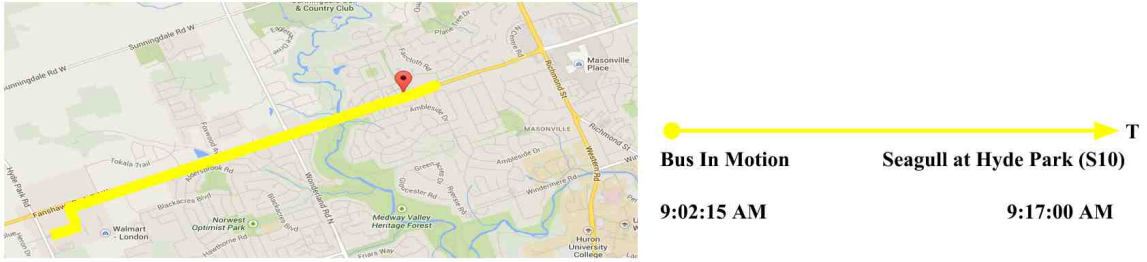

**Figure 5-5: Crowding level is YELLOW at 9:02:15 AM showing light crowding expected.**



**Figure 5-6: Crowding level is RED at 9:06:12 AM showing heavy crowding expected.**

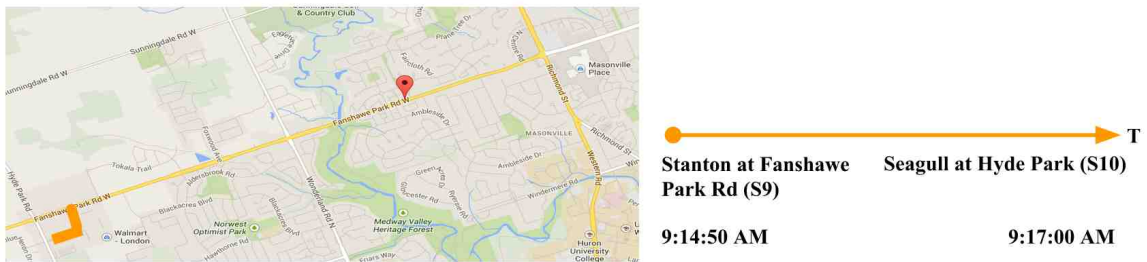

**Figure 5-7: Crowding level is ORANGE at 9:14:50 AM showing moderate crowding expected.**

## 5.5 Future deployment in the Transit Office Environment

TraDEPS is yet to be deployed in the real-world office environment. However, when implemented, a transit operation center can view the estimated crowding levels on all of the critical routes and the capacity of each bus, allowing the agency to dispatch additional buses, known as express buses, to routes that will become crowded, say about 10 minutes

ahead from the time measured. The transit office receives notification messages for the different crowding levels at a given time. Customers are also informed of potential crowding in the future and the best alternative routes via mobile applications and the web. The results are computed using real-time data analytics powered by TraDEPS in combination with the crowding prediction model discussed in Chapter 3. This is likely to provide efficient usage of the transit vehicles while preventing the incidence of crowding rather than just increasing the frequencies of services on a route to prevent overcrowding.

# Chapter 6

## 6 DISCUSSION

### 6.1 Benefits for Public Transit Management

The main goal behind the transit analytics, predictions and visualizations is to provide alerts and a view of the near future crowding level to the transit managers so that action can be taken before transit crowding occurs. It also provides customers with smartphones and access to the web about crowding in the future and the best alternative routes. It is non-intrusive since it does not require the installation of an application from an application repository on a smartphone and does not impact the performance of the smartphones e.g. draining the battery.

### 6.2 Drawbacks

#### Smartphone Penetration

If every passenger waiting at the stop were carrying a smartphone, calculating the statistics on number of waiting passengers would be very easy. Smartphone penetration by percentage in different countries is usually published but this may vary very widely for each bus stop on a specific route. This may not give accurate results when ascertaining the actual number of passengers present or waiting at each bus stop based on the devices.

## **Multiple Routes**

The system works best if there is only one route at each stop. However, there may be several routes for a particular bus stop. As a result, the data collected may be tainted and inaccurate.

## **Perception of Privacy**

It is possible that many transit riders that own devices are not aware of being tracked by the system. Once they are aware, then the notion of privacy may become very important to them. Some riders may not feel comfortable if their digital presence is being tracked as they may think their personal information is being collected or phone hacked.

## **Re-Identification**

Data that is anonymized may be re-identified thereby revealing the privacy of the riders.

## **Wi-Fi State**

Wi-Fi must be enabled on the rider's smartphone for the Wi-Fi node to be able to collect data from the rider. Some riders may be uncomfortable with data being collected and disable the Wi-Fi on their smartphones. Turning off Wi-Fi by a rider to conserve battery and extend the battery life of a smartphone is also possible.

# Chapter 7

## 7 CONCLUSIONS AND FUTURE WORK

### 7.1 Conclusions

Real-time transit data can now be collected and data visualization of transit conditions provided based on Wi-Fi sensors that can track smart devices equipped with Wi-Fi. This is especially helpful for public transit managers for decision-making before transit crowding actually occur.

Leveraging on distributed tracking and monitoring, the transit demand estimation and prediction system, an end-to-end system, can aggregate data from many Wi-Fi sensors deployed across different bus stops and routes and time periods. Combining the data feeds with data from other sources provides for effective analysis and presentation of this data for transit management.

With this approach to transit management, there is a need to ensure the privacy of riders. Security measures are maintained by encrypting data before transmission, making sure the MAC address data is anonymized and modified to an extent where it is very difficult to derive the initial MAC address. By addressing privacy concerns and building a scalable system that can be used in many stop locations and public transit, municipal transit agencies can look forward to providing information about transit conditions in real-time and better management of transit crowding.



## 7.2 Contributions

In our work, we describe our approach for estimating passenger demand based on real-time data. We created a modular system for sensing devices and discovering passenger presence at the bus stops, counting and collating the presence data on a central server. We have shown that our approach is useful in discovering passenger presence in the condition of constrained and practical deployment requirements.

We proposed a crowding prediction model for a transit demand estimation and prediction system (TraDEPS) to reveal when the bus will be full or crowded during a trip. We have shown that crowding levels can be predicted/estimated using simple prediction model based on real-time data although crowding is known to be pretty random. The results suggest that the model may be appropriate for deployment to determine when the transit vehicle will become crowded at a transit operations center. It can provide several minutes of advance notice before crowding will occur. This several minutes of warning may allow managers and staff members to take action to alleviate crowding. Possible action includes the dispatch of an additional bus. In addition, the results show that analysis information concerning crowding levels can be included in the Advanced Traveller Information Systems (ATIS) to provide advice to the transit riders ahead of time.

## 7.3 Limitations

The present work has a limitation that merit discussion. Because we have used simulated data instead of real data, it is difficult to validate how successful this approach to reveal transit crowding will be if the devices were deployed in the real-world. Due to the drawbacks inherent in this approach, it may be difficult to get an accurate count of the people at the bus stops. The worst case scenario would be that no one comes along to a bus stop with a smartphone device.

## 7.4 Future Work

Future extensions of the present work might include assessing the impact of weather, historical data, events, social media data, locales and traffic on the implementation taking the following into consideration:

- Live bus arrival data feed
- Historical data of the number of riders on a bus
- Historical data of the passenger demand on different routes
- Local events data: Municipality events information (location, event type, description, category)
- Commercial venue data: categorization and descriptions of all commercial venues, including GPS locations.
- Hourly weather data: temperature, temperature with wind chill, rain/sun/snow
- Facebook stream: all geocoded posts within a municipality
- Google+ stream: all geocoded posts within a municipality
- Tweet stream: all geocoded tweets within a municipality
- Central server sending notification message to the transit operations sender and clients when the bus will be full.

Compared to real-world data, simulated data used in the analysis are generally ideal but lack practicability. With real-world data, the prediction model could be tested and improved to ensure overall prediction results with a very high percentage of accuracy. A better prediction model or sophisticated algorithm could be developed in the future for crowding predictions. This could include factors such as time, distance, and aggregated volumes of waiting passengers about two to four bus stops away from the current location of the bus as well as the aggregated volumes of waiting passengers near the end of the trip. The techniques of encryption, decryption, compression and decompression could be implemented in the future to make the system more robust.

## 8. BIBLIOGRAPHY

- [1] **Veitch, T., J. Partridge, and L. Walker:** "Estimating the costs of over-crowding on Melbourne's rail system." Australasian Transport Research Forum (ATRF), 36th, 2013, Brisbane, Queensland, Australia, pp. 1, 2013 [Online]  
[http://www.atrf.info/papers/2013/2013\\_veitch\\_partridge\\_walker.pdf](http://www.atrf.info/papers/2013/2013_veitch_partridge_walker.pdf), Accessed July 2014.
- [2] **Qin, Feifei:** "Investigating the In-vehicle Crowding Cost Functions for Public Transit Modes", Mathematical Problems in Engineering, vol. 2014, Article ID 502708, 13 pages, pp. 8, 2014. doi:10.1155/2014/502708 [Online]  
<http://www.hindawi.com/journals/mpe/2014/502708/>. Accessed July 2014
- [3] **Google Maps traffic** (<https://www>), [Online]  
[support.google.com/maps/answer/3093389/](http://support.google.com/maps/answer/3093389/) website. Accessed June 2014
- [4] **Measuring transit demand** (<http://www>),  
[Online] [en.wikibooks.org/wiki/Fundamentals\\_of\\_Transportation/Transit\\_Demand/](http://en.wikibooks.org/wiki/Fundamentals_of_Transportation/Transit_Demand/)  
website. Accessed June 2014
- [5] **Healy, R., Kapilian, R.:** Passenger Counting and Service Monitoring, pp. 9, 2003,  
(<http://www>) [Online] [ntl.bts.gov/lib/23000/23600/23620/psgr\\_ctg\\_svc\\_mon.pdf](http://ntl.bts.gov/lib/23000/23600/23620/psgr_ctg_svc_mon.pdf),  
website. Accessed July 2014
- [6] **Fuerstenberg, K.C., Dietmayer, K.C.J., Willhoeft, V.:** 'Pedestrian recognition in urban traffic using a vehicle based multilayer laser scanner'. IEEE Intelligent Vehicle Symp., vol. 1, pp. 31–35, June 2002.
- [7] **Oberli, C., Torres-Torriti, M., Landau, D.:** 'Performance evaluation of UHF RFID technologies for real-time passenger recognition in intelligent public transportation systems', IEEE Trans. Intell. Transp. Syst., vol. 11, issue 3, pp. 748–753, 2010.
- [8] **Bi, L., Tsimhoni, O., Liu, Y.:** 'Using image-based metrics to model pedestrian detection performance with night-vision systems', IEEE Trans. Intell. Transp. Syst., vol. 10, issue 1, pp. 155–164, 2009.

- [9] **Kilambi, Prahlad, et al.:** "Estimating pedestrian counts in groups." *Computer Vision and Image Understanding* 110.1, pp. 43-59, 2008 doi: 10.1016/j.cviu.2007.02.003.
- [10] **CRTC issues annual report on the state of the Canadian communication system** (<https://www.crtc.gc.ca/eng/com100/2013/r130926.htm/> website. Accessed July 2014
- [11] **Canadian Smartphone Adoption at 62% comScore says** (<https://www.iphoneincanada.ca/news/canadian-smartphone-adoption-at-62-comscore-says/> website. Accessed July 2014.
- [12] **Raspberry PI** (<https://www.raspberrypi.org/> website. Accessed July 2014.
- [13] **Arduino** (<https://www.arduino.cc> website. Accessed July 2014.
- [14] **Torres, Neftali:** "Advance Traveler Information Systems." (2008). (<https://www.its-ct.org/documents/StudentGrant/ATISreport2008-09.pdf> Accessed July 2014.
- [15] **Navick, D. and Furth, P.:** Estimating Passenger Miles, Origin-Destination Patterns, and Loads with Location Stamped Farebox Data, *Transportation Research Record*, 1799, pp. 107-113, 2002.
- [16] **Travlink Operational Test Evaluation Report**, Minnesota Department of Transportation, Guidestar Office, pp. 1, 1996, ([https://www.ntl.bts.gov/lib/jpodocs/repts\\_te/2583.pdf](https://www.ntl.bts.gov/lib/jpodocs/repts_te/2583.pdf) website. Accessed July 2014.
- [17] **Bruce Wetherby:** "Seattle Wide-Area Information for Travelers (SWIFT): Evaluation Summary." Science Applications International Corporation, pp. 5, 1998, ([https://www.ntl.bts.gov/lib/jpodocs/repts\\_te/7404.pdf](https://www.ntl.bts.gov/lib/jpodocs/repts_te/7404.pdf) website. Accessed July 2014.
- [18] **Ferris, Brian, Kari Watkins, and Alan Borning:** "Location-aware tools for improving Public transit Usability." *IEEE Pervasive Computing* 9.1, pp. 13-19, 2010.

- [19] **TCRP Report 58:** New paradigms for Local Public Transportation Organizations – Task 5 Report: Opening the Door to Fundamental Change, Transportation Research Board of the National Academies, Washington, DC: pp. 15, 2000, ([https://www.tcrponline.org/PDFDocuments/tcrp\\_rpt\\_58.pdf](https://www.tcrponline.org/PDFDocuments/tcrp_rpt_58.pdf)) website. Accessed July 2014.
- [20] **Markovic, H., Basic, B.D., Gold, H., Dong, F., Hirota, K.:** GPS data-based non-parametric regression for predicting travel time in urban traffic networks. *Sci. Traffic Transport* vol. 22, issue 1, pp. 1–13, 2010.
- [21] **Wu, C.H., Ho, J.M., Lee, D.T.:** Travel-time prediction with support vector regression. *IEEE Trans. Intell. Transportation System* 5(4), pp. 276–281, 2004.
- [22] **Zhang, X., Rice, J.A.:** Rice. "Short-term travel time prediction." *Transportation Research Part C: Emerging Technologies* 11, no. 3 (2003): 187-210.
- [23] **Rzeszotko, J., Nguyen, S.H.:** Machine learning for traffic prediction. *Fundam. Inf* 119(3-4), pp. 407–420, 2012.
- [24] **Dunne, S., Ghosh, B.:** Weather adaptive traffic prediction using neurowavelet models. *IEEE Trans. Intell. Transportation Syst* 14(1), pp. 370–379, 2013.
- [25] **Mazloumi, E., Rose, G., Currie, G., Moridpour, S.:** Prediction intervals to account for uncertainties in neural network predictions: methodology and application in bus travel time prediction. *Eng. Appl. Artif. Intell* 24(3), pp. 534–542, 2011.
- [26] **van Hinsbergen, C.P.I.J., Hegyi, A., van Lint, J.W.C., van Zuylen, H.J.:** Bayesian neural networks for the prediction of stochastic travel times in urban networks. *IET Intell. Transport Syst* 5(4), pp. 259–265, 2011.
- [27] **Comert, G., Bezuglov, A.:** An online change-point-based model for traffic parameter prediction. *IEEE Trans. Intell. Transportation Syst* 14(3), pp. 1360–1369, 2013.
- [28] **Min, W., Wynter, L.:** Real-time road traffic prediction with spatio-temporal correlations. *Transportation Res. Part C* 19, pp. 606–616, 2011.

[29] **Xia, J., Chen, M., Huang, W.:** A multistep corridor travel-time prediction method using presence-type vehicle detector data. *J. Intell. Transportation Syst: Technol. Plann. Oper* 15(2), pp. 104–113, 2011.

[30] **Vijayan, V.P., Paul, B.:** Multi objective traffic prediction using type-2 fuzzy logic and ambient intelligence. *Proceedings of 2010 International Conference on Advances in Computer Engineering (ACE)*, pp. 309–311, 2010

[31] **Li, L., Lin, W.H., Liu, H.:** Type-2 fuzzy logic approach for short-term traffic forecasting. *IEE Proc. Intell. Transport Syst* 153(1), pp. 33–40, 2006.

[32] **Ghosh, B., Basu, B., O'Mahony, M.:** Multivariate short-term traffic flow forecasting using time-series analysis. *IEEE Trans. Intell. Transportation Syst* 10(2), pp. 246–254, 2009.

[33] **Smith, B.L., Williams, B.M., Oswal, R.K.:** Comparison of parametric and nonparametric models for traffic flow forecasting. *Transportation Res. Part C* 10(4), pp. 303–321, 2002.

[34] **Wang, Y., Papageorgiou, M.:** A Messmer, Real-time freeway traffic state estimation based on extended kalman filter: a case study. *Transportation Sci* 4(2), pp. 167–181, 2007.

[35] **Chen, M., Chien, S.I.J.:** Dynamic freeway travel-time prediction with probe vehicle data: link based versus path based. *Transportation Res. Rec* 1768, pp. 157–161, 2001.

[36] **Ahn K., Rakha H., Hill D.:** Data quality white paper. No. fhwa-HOP-08-038. US Department of Transportation, Federal Highway Administration, pp. 14-15, 2008.

[37] **Balmer, M., Nagel, K., Raney, B.:** "Large-scale multi-agent simulations for transportation applications." *Intelligent Transportation Systems*. Vol. 8. No. 4. Taylor & Francis Group, pp. 1-16, 2004.

[38] **Payne, H.J.:** "FREFLO: A macroscopic simulation model of freeway traffic." *Transportation Research Record* 722, pp. 68-77, 1979.

- [39] **IEEE OUI Registry** (<https://standards.ieee.org/develop/regauth/oui/oui.txt>), [Online] website. Accessed July 2014.
- [40] **Wireshark** (<https://www.wireshark.org>), [Online] website. Accessed July 2014.
- [41] **Google Maps** (<https://www.google.com/mobile/maps>) website. Accessed July 2014
- [42] **Wireless Networks** ([https://www.technologyuk.net/telecommunications/networks/wireless\\_networks.shtml](https://www.technologyuk.net/telecommunications/networks/wireless_networks.shtml)) website. Accessed July 2014
- [43] **Ramesh, G., Umarani, R.:** "Performance Analysis of Most Common Encryption Algorithms on Different Web Browsers." International Journal of Information Technology and Computer Science (IJITCS) 4.12 (2012): 60.

## Curriculum Vitae

<b>Name:</b>	Michael Aro
<b>Post-secondary Education and Degrees:</b>	VAMK – Vaasan ammattikorkeakoulu Vaasa, Finland BEng, Information Technology
<b>Honours and Awards:</b>	Western Graduate Research Scholarship 2012–2013
<b>Related Work Experience</b>	Teaching Assistant Western University 2012-2013